

NOTE: This is an installation *supplement*. Please refer to the original IOM for all applicable products before using this document.



APPLICATION:

The following installation instructions supplement is intended for CVS-SAFE4 models FD or FDD Fire Dampers and model FSD Combination Fire/Smoke Dampers. This installation supplement will show how to install these dampers in a fire rated wood or steel stud constructed wall.

INSTALLATION NOTES FOR WOOD/STEEL STUD FRAMING:

1. Frame wall openings as shown (see figure 3 and 4). Double vertical studs are not required for openings 36" (914mm) wide by 36" (914mm) high or smaller (see Figure 3).
2. When using wood studs, filler pieces are required to be installed around the entire opening so the damper is not in direct contact with the wood studs and screwed to the web of runners and studs (see Figure 2). Filler pieces are optional when using metal studs (see Figure 1).
3. Full length studs are not required next to the damper if the spacing from the damper to the full length stud does not exceed the maximum stud spacing. The opening may be framed with studs that are attached to the full length studs (see Figure 4).
4. All construction and fasteners must meet the requirements of the appropriate wall design and/or local codes. Consult with the AHJ (Authority Having Jurisdiction) for alternate framing methods.

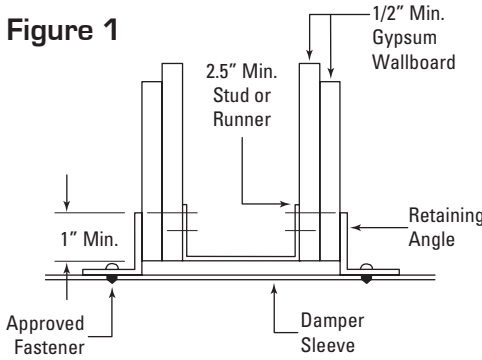

Figure 1
2 Hour Rating Wall Shown
(Consult UL Fire Resistance Directory for Wall Construction)

